

DA

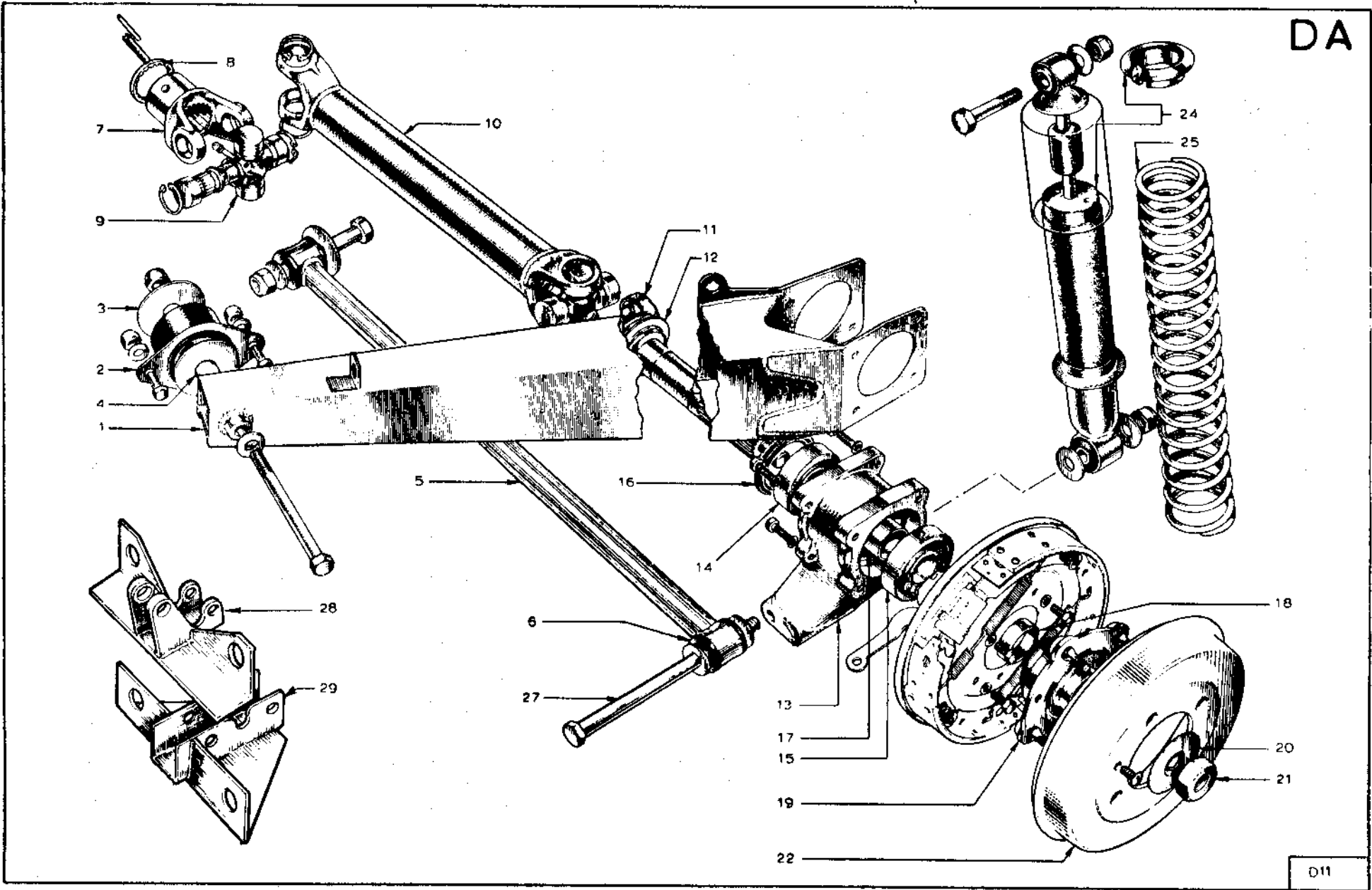

D11

PLATE	PART NO.	QUANTITY					STEERING		DESCRIPTION	CHANGE POINT	BULLETIN R
		ALL	T/C	T/C Fed.	Special	Spec. Fed.	LH	RH			
Ref: No.											
DA1	A074 D 0197Z		1	1			*	*	Arm. Radius, - L/H,		
	A074 D 0217Z				1	1	*	*	Arm. Radius, - L/H.		
	A074 D 0198Z		1	1			*	*	Arm. Radius, - R/H.		
	A074 D 0216Z				1	1	*	*	Arm. Radius, - R/H.		
DA2	X046 D 6000Z	2							Mounting. Resilient,		
	36A	2							Bolt. Mounting to Arm		
	128	2							Washer.		
DA3	A07W 3212	2							Washer.		
	218	2							Nut.		
	13	4							Bolt. Mounting to Chassis.		
	119	4							Washer.		
	211	4							Nut.		
DA4	A074 D 0205Z	AR							Shim. Radius Arm, - 1/8 ins.		
	A074 D 0206Z	AR							Shim. Radius Arm, - 1/16 ins.		
DA5	B074 D 0195Z	2							Link. Lower,		
DA6	A074 D 6002Z	4							Bush. Lower Link,		
	37	2							Bolt. Link to Gearbox,		
	128F	4							Washer.		
	219	2							Nut.		
	A074 D 0756W		2	2			*	*	Assembly. Drive Shaft, (use with Type 336 Gearbox)		

PLATE Ref: No.	PART NO.	QUANTITY					STEERING		DESCRIPTION	CHANGE POINT	BULLETIN RE	
		ALL	T/C	T/C Fed.	Special	Spec. Fed.	LH	RH				
	A074 D 0749W	2							Assembly. Drive Shaft, (use with Type 352/365 Gearboxes.)			
DA7	A074 D 6006Z		2	2			*	*	Yoke. (for A074 D 0756W)			
	A074 D 6010Z	2							Yoke. (for A074 D 0749W)			
DA9	A074 D 6008Z	4							Joint. Universal,			
DA10	A074 D 6004Z	2							Shaft. Inboard Drive,			
DA11	A074 D 6005Z	2							Shaft. Outboard Drive,			
DA12	A074 D 0196Z	2							Flinger.			
DA8	X046 R 0022Z	AR							Ring. Spacer, (0.405 ins. Undersize)			
	X046 R 0023Z	AR							Ring. Spacer, (0.410 ins. Undersize)			
	X046 R 0024Z	AR							Ring. Spacer, (1 <sup>st</sup> Oversize)			
	X046 R 0025Z	AR							Ring. Spacer, (2 <sup>nd</sup> Oversize 0.420 ins.)			
	X046 R 0026Z	AR							Ring. Spacer, (3 <sup>rd</sup> Oversize)			
	A054 D 0187Z	AR							Shim. (0.005 ins.)			
	A054 D 0188Z	AR							Shim. (0.015 ins.)			
	X046 R 6000Z		2	2					Pin. (Outer) Drive Shaft to G/Box.	} Use on A074 D 0756W		
	X046 R 6001Z		2	2					Pin. (Inner) Drive Shaft to G/Box.			
	A074 F 6013Z	2							Pin. Drive Shaft to G/Box. (Use on A074 D 0749W)			
DA13	B074 D 0193Z		1	1			*	*	Housing. Bearing, - L/H.			
	E074 D 0193Z				1	1	*	*	Housing. Bearing, - L/H.			

0972.

DA2.

PLATE Ref: No.	PART NO.	QUANTITY					STEERING		DESCRIPTION	CHANGE POINT	BULLETIN
		ALL	T/C	T/C Fed.	Special	Spec. Fed.	LH	RH			
	B074 D 0194Z		1	1			*	*	Housing. Bearing, - R/H.		
	E074 D 0194Z				1	1	*	*	Housing. Bearing, - R/H.		
	10	8							Setscrew. Attaching,		
	116	8							Washer.		
DA14	A074 D 6001Z		2	2			*	*	Bearing. Inner,		
	X036 D 6017Z				2	2	*	*	Bearing. Inner,		
DA15	X036 D 6017Z	2							Bearing. Outer,		
DA16	A074 D 6000Z		2	2			*	*	Seal. Bearing,		
	A074 D 6009Z				2	2	*	*	Seal. Bearing,		
DA17	X046 D 0148Z		2	2			*	*	Spacer. Bearing,		
	A074 D 0215Z				2	2	*	*	Spacer. Bearing,		
DA18	A074 D 0208Z	2							Spacer. Hub,		
DA19	A046 D 0001Y		2	2			*	*	Hub.		
	A074 D 0214Y				2	2	*	*	Hub.		
DA20	X046 D 6006Z	2							Washer. Hub Retaining,		
DA21	X046 D 6007Z	2							Nut. Hub Retaining,		
DA22	X046 J 6023Z		2	2			*	*	Drum. Brake,		
	A074 J 6036Z				2	2	*	*	Drum. Brake,		
	KUFS 0408	1							Screw. Drum to Hub Attaching,		
	X036 D 6002Z	16							Stud. Road Wheel Securing,		
	D074 D 0757W	2							Assembly. Damper/Spring,		

PLATE Ref: No.	PART NO.	QUANTITY					STEERING		DESCRIPTION	CHANGE POINT	BULLETIN REF.
		ALL	T/C	T/C Fed.	Special	Spec. Fed.	LH	RH			
DA24	A074 D 6007W	2							comprising, Damper Assembly, Spring.		
DA25	B026 C 0010A	2									
DA27	A074 D 0209Z	2							Bolt. Damper /Lower Link to Housing,		
	129	4							Washer.		
	128F	4							Washer.		
	219	2							Nut.		
	37	2							Bolt. Damper to Cross Beam,		
	129	2							Washer,		
	219	2							Nut.		
DA28	C074 A 0721W	1							Mounting. Lower Link to Type 352/365 Gearbox.		
DA29	B074 A 0716W		1	1			*	*	Mounting. Lower Link to Type 336 Gearbox.		